

Central Asiatic Journal

1x(2) 1964

A STUDY OF THE *LDAB LDOB**

by

MELVYN C. GOLDSTEIN

Seattle

The data on which this paper is based were obtained from formal interviews and informal discussions with five Tibetans living in Seattle, Washington. The interviews were held at the University of Washington from February to August, 1963. My wife, Chunden Surkhang-Goldstein, acted as my translator. She is a bilingual native Tibetan who is a language consultant for the Inner Asia Project of the Far East and Russian Institute of the University of Washington. The first interviews were taped and on-the-spot translations were later checked carefully by Mrs. Goldstein. When we found that the working notes from the interviews correspond to the tape of the sessions, we abandoned tapes. The informal discussions – from card games to quiet evenings at one of our homes – were held at various places, and often several informants were present. Later we rephrased the new information collected at these sessions and again questioned the informants individually. At many of the informal sessions I deliberately made an erroneous generalization concerning material I had already gathered to ascertain whether the informants would correct me. They always did.

Although my sample is limited, it represents all major areas of Tibet except for *A mdo* (which in modern times was not under the political control of the Tibetan government) and Western Tibet. The following short biographies emphasize the qualifications of the informants concerning the question of *Ldab ldob*.

Ngag dbang Nor nang: He was born in Lhasa about thirty-five years ago. By birth he was a member of the aristocracy. Before his teens he

* This paper was originally presented at the Inner Asia Research Project Colloquium of the Far East Institute at the University of Washington. Tibetan words are transcribed according to the transcription by Professor Turrell V. Wylie cited in "A Standard System of Tibetan Transcription", *Harvard Journal of Asiatic Studies*, XXII (December, 1959).

entered the monastic order at the monastery of *Bshad sgrub gling*, a *Dge lugs pa* institution located in Southeast-Central Tibet (*Dwags po*). For about eight years he handled, among other things, all the secular business of that monastery (for example, trading and loans), and in the execution of this work he traveled repeatedly throughout most of Central Tibet, many parts of Southwest Tibet (*Gtsang*), and on several occasions Northern Tibet. He had dealings with people at all levels of the society, and had many friends, from thieves to abbots of monasteries. *Nor nang* spent a great deal of time in Lhasa each year and knew many *Ldab ldobs* personally; he was also a member of a *Ldab ldob Gling ka skyid sdug* (discussed later, pp. 130, 131). His excellent recall of details was invaluable. Careful to differentiate between personal experience and hearsay, he often qualified statements by saying that he had heard this but not actually seen it and didn't want to be quoted except on those terms. Since he is related to me through my wife's maternal family, he was never reticent about discussing "delicate" subjects.

Sde gzhung Rin po che: He was born in the village of *Stag lung* in Eastern Tibet (*Khams*) in 1906, the child of a middle-class peasant family. At the age of five he entered the monastic order and was subsequently found to be an incarnation of the *Sa skya* sect. He spent the majority of his life in *Khams*, but also lived for some time in *Gtsang*. Like *Nor nang*, he has a tremendous recall for details and great caution concerning what he has seen or heard. Because one of his religious "specialities" was divination, he had intimate dealings with the lay population of *Khams* on topics as diverse as marriage and business investments.

Bkra shis Tshe ring: He is a layman who was born in *Gtsang* (*Shangs*) in 1932. Since he was a member of the "dancing troop" of the Dalai Lama (*Gar phrug pa*) as a youth, he spent much of his life in Lhasa, although he also lived in *Gtsang* at various times. He had friends who were *Ldab ldobs* in both areas.

Lha sgron Skyar srib: She was born in Lhasa in 1941, a member of the aristocracy. She is married and has a four-year-old son. Most of her life has been spent in and around Lhasa, but she has lived on her estates in *Gtsang*. Although she went to English school in India for several years, *Skyar srib* had a very traditional upbringing in Tibet.

Chos ldan Zur Khang (Goldstein): She was born in Lhasa in 1940, a member of the aristocracy. While in Tibet, she lived in Lhasa; she has studied at an English school in India, Cottey College in Missouri, and is presently at the University of Washington.

I offer these biographical details because of problems involved in

securing information from a small group of people. I hope that, given the range of experience and age of the informants and the checks used in the methodology, the data are accurate.

About 95 per cent of the new monks in Tibet enter the monastery either during or before their teens. Most new monks are in their mid-teens, but a substantial number enter between seven and thirteen years of age. Many of the younger boys, regardless of how they view monkhood, are put into monasteries by their parents. At some time during their early career, the monk-youths feel sad and unhappy in the monastery. They are homesick. They want to go out and play like other young boys. They want to shout, to fight, to wander in the fields. They want to do the things they are prohibited from doing by virtue of their role as monks. Some of these young monks leave the monastery at this time and return home. But most of these soon return to the monastery for reasons explained below (pp. 137, 138). The rest of the youths stay and make the best of it. Most of them get over their sadness and remain in the monastery without any inner resentment or aggressive tendencies, going the normal route in the monastic system. At about the age of eighteen, they must decide whether they will go on to read the advanced texts, a decision which depends upon individual disposition and intelligence. Those monks who either will not or cannot read the advanced texts cause no problem to the system; they read the less difficult texts and do various physical jobs around the monastery.

But in a closed system (see p. 137) one would expect, and indeed finds, deviants. There are monks who simply are unable to abide by the monastic laws. They are aggressive and pugilistic. They desire many of the pleasures of the layman's life, but remain in the monastic system because of the economic and prestigious incentives the system offers. These monks, I suggest, step into the ready-made channel which the system offers them: the role of the *Ldab ldob*. Here they can reach a compromise between their vows as monks and their secular desires without losing their status and function in the monastic system.

The phenomenon of the *Ldab ldob* within the monastic segment of Tibetan society is unique. This paradoxical group, which numbers as high as 10 per cent of the monk-population of the larger monasteries, seems to flaunt and make ridiculous the monastic system. One of the sayings which the *Ldab ldob* proudly though facetiously use to describe themselves illustrates this nicely:

Sangs rgyas nam mkha' la byon la na'ang dad pa mi shes/
Sems can rgyu ma lug na'ang snying rje mi shes mkhan//

Even if the Buddha appeared in the sky we (*Ldab ldobs*)
would not know how to have faith,
Even if the intestines of a sentient being were falling out,
we (*Ldab ldobs*) would not know how to have compassion.

Although the *Ldab ldob* lives in a monastery, has taken monastic vows, wears basically the dress of a Buddhist monk, and considers himself to be a monk, he is at first glance more of an anti-monk than a "real" monk. His behavior seems to put him in a category with the worst secular Buddhists, according to a large portion of the Buddhist texts. As evident as this may seem to the outsider, neither secular nor monastic Tibetans hold this view, and therefore we cannot facily pass off the *Ldab ldob* as a bad monk. We can understand the paradox of *Ldab ldob* if we examine them according to what they do, how they dress, their role in the monastic society, how they are viewed by the members of the whole society, certain characteristics of the monastic institution, and the functional role of *Ldab ldobs* as a group. I will discuss these aspects in two sections: a first section of descriptive data, a second of analytical observations.

A few background remarks on the monastic institution may be helpful. From the latter part of the ninth century, when the Kingdom disintegrated, the history of Tibet can be characterized by a struggle for power in the vacuum left by the breakdown of the Kingdom. At first this struggle was mainly between the nobles who seized the authority which was once held by the King in their own localities. Transplanted Buddhism soon established firm roots and entered the struggle. Presently one of the religious sects, *Dge lugs pa*, won out over its rivals, but the victory, even up to 1950, was not complete. Although final authority rested in the hands of the Dalai Lama, or the Regent who ruled in his place during his minority, there was a complicated system of checks and balances, and endless intrigue on all higher levels of government. As recently as 1947, a revolt, headed nominally by the former Regent *Rwa sgreng Rin po che* and backed actively by the monks of *Rwa sgreng* and *Se ra* monasteries, both of which are in the vicinity of Lhasa, was crushed by the Tibetan army. The contemporary monastic system is the result of centuries of strife, warfare, and intrigue, as well as sincere reforms and religious fervor.

While there is no way to ascertain what the population of monks in Tibet was, the usual figures range from 10 to 20 per cent of the population and thus perhaps as much as 40 per cent of adult males. The monks

stayed in monasteries whose populations varied from four to five to eight or nine thousand. The three great monasteries around Lhasa – *Bras spungs*, *Dga' ldan*, and *Se ra* – alone numbered about twenty thousand monks. The larger monasteries were not merely centers for religious study and meditation, but were also large landholders. They often engaged in trading and moneylending, and they had their own craftsmen and administrative hierarchy.

Ldab ldob is a term used to distinguish a type of monk who is found throughout Tibet, especially in larger monasteries. Within the monastic system itself, there is no official name for *Ldab ldobs*. They are named simply according to their "rank": *Dge tshul*, *Dge slong*, *Mkhan po*, and so forth.

To all of my informants, the term *Ldab ldob* referred to a monk whose physical appearance and dress were easily distinguished from the rest of the monastic population and whose behavior was also distinctive. Every *Ldab ldob* does not necessarily demonstrate each of the items I will mention, nor do all *Ldab ldobs* have any given item to the same degree. But in general, *Ldab ldobs* differ from the regular Buddhist monks in the following ways:

Instead of the long, wrapped lower dress (*Sham thabs*) of a "normal" monk, a *Ldab ldob* wears his lower dress raised up from the ankles and very heavily pleated. His lower dress is twice as long as other monks and doubled over at the belt so that this added part will hang to about the knees. The pleats of the lower dress, added to the hip-swaying walk of the *Ldab ldobs*, give the dress a characteristic swinging motion in walking.

While a "normal" monk wears his upper dress (*Gzan*) like a sash, a *Ldab ldob* wears his like a scarf, with both ends thrown over the shoulders.

Other monks have shaven heads, but a *Ldab ldob* has a lock of hair known as *Rna skra*. The *Ldab ldob* allows a lock of hair to grow behind each ear; he shapes this *Rna skra* to resemble a curved horn and wraps it around his ears.

A *Ldab ldob* wears a piece of red cloth called *Rtsa sdom* tied above the elbow on his right arm in Central Tibet or tied on both arms in *Khams*. While this may be tied with a rosary, it is not the usual procedure.¹

In order to appear more ferocious, the *Ldab ldob* uses eye shadow called *Dreg nag*. It is soot from the bottom of a tea pot mixed with grease left at the bottom of a tea cup (a monk's tea is made with a huge amount of butter, and is very greasy). A *Ldab ldob* works the soot and grease

¹ This is a contradiction of a suggestion by R. A. Stein in *La Civilisation Tibétaine*, p. 113.

into a mixture and smears it above and beneath his eyes with his palms.

In *Khams* the *Ldab ldobs* keep their snuff in a reconverted Yak's horn, not in a box.

The dress of the *Ldab ldob* consists of at least one weapon. The most common one is the *Lde brdzus*, the imitation key (see diagram below). This key is made like any other Tibetan key, except that it has a long leather handle attached to it with a knotted grip at its end, extending the length of one arm spread (*'Dom*). The *Ldab ldobs* spend a great deal of time perfecting the technique of throwing out and retrieving this key (using mainly the wrists, much like we throw a yo-yo, but without winding up the attached string). This *Lde brdzus* is easily the match of a sword since it outreaches the sword and can inflict a serious wound on the opponent before the sword can get close enough to do any harm.

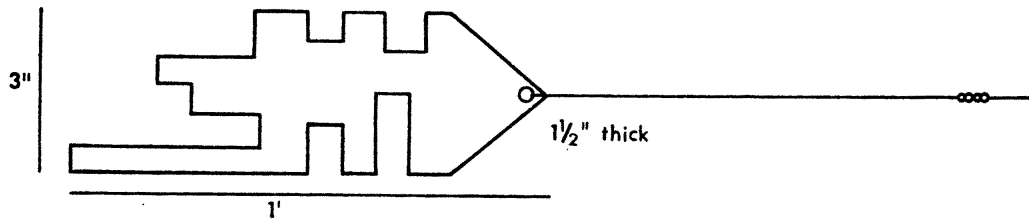

Lde brdzus

The *Khye'u*, or *Lcags sag* as it is called in *Khams*, is another type of knife carried by the *Ldab ldob*. It is mainly used by shoemakers for cutting leather, but has been adapted for other uses by the *Ldab ldobs*. From a distance it is thrown like the key, but at close range it is handled like a knife. The *Khye'u* can be worn with or without a *Lde brdzus*.

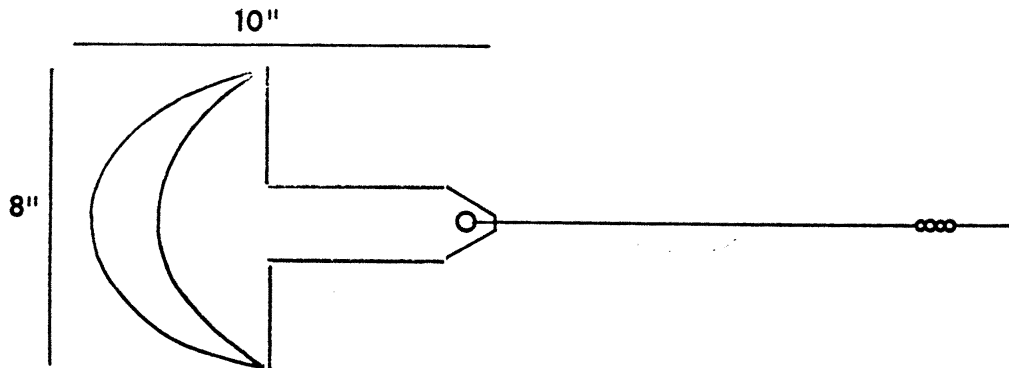

Khye'u

While these are the weapons most commonly associated with *Ldab ldobs*, they can carry others. Many *Ldab ldobs* carry a long knife which is

hidden beneath the robe on their backs (the *Lde brdzus* and *Khye'u* are worn hanging from the belt). In summary, the dress and physical appearance of a *Ldab ldob* are distinctive and distinguish him from the other Buddhist monks.

Another aspect of a *Ldab ldob's* behavior which singles him out from the rest of the monastic order is his penchant for competing in sports, formal or informal. One of the most interesting games is *Mchong*, which occurs in Lhasa as a special form of competition between *Se ra* and *'Bras spungs* monasteries. It is the only official intermonastery sport and is performed only by *Ldab ldots*, although not necessarily by all the *Ldab ldots*. The playing field for *Mchong*, called *Mchong ra*, is not a permanent structure, but is built anew each time an intermonastery meet occurs. Usually a meet is held every few years, but it is not held at any set time of the year. After the site for the *Mchong ra* is selected by the monasteries, the construction begins of a sloped runway made of rocks plastered with mud which will be about fifty feet high and no more than three feet wide. At the top of the slope there is a flat area about one and one-half feet by three feet. The resulting structure is a right triangle with flat top, underneath which a jumping pit is dug and filled with loose earth to soften the shock of the fall.

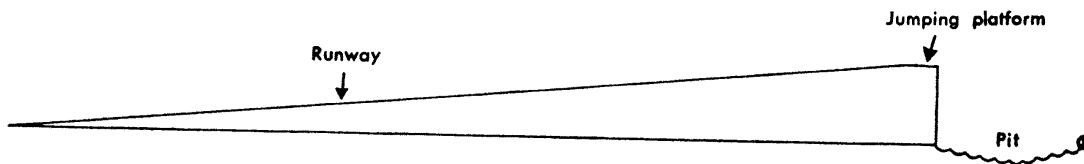

In this type of competition, there are six events, and they take one day to complete. In all of the events which use stones, the stones are carefully weighed to assure that they are equal in weight. The events are: (1) The contestant runs up the runway; when he reaches the small flat area called the jumping platform (see diagram), he must stamp his right foot within that area and then jump. The winner is decided by the distance of the jump. (2) The contestant carries in his hand a triangular-shaped knife called a *Phur pa*. The procedure is the same as in event (1) until the contestant begins his jump. At the time his feet touch the ground, he must in one motion place the *Phur pa* at the intersection of the ground with the pit level (see X in diagram). In the running broad jump event the situation is similar, for if the contestant lands off balance and falls backward, he loses considerable distance. In the Tibetan event the contestant who falls backward has no chance of placing the *Phur pa* near

the intersection. (3) In this event the contestant wears a white scarf which hangs from his neck and is tied so that it is circular. When he reaches the jumping platform, he must, while still running, jump through the scarf so that it remains on the jumping platform, and then jump to the pit. If both contestants are able to jump through the scarf, the distance of the jump determines the winner. (4) There is no run up in this event, called *Rgyab rdo*. The contestant stands at the very edge of the jumping platform, balanced on the balls of his feet with his back facing the perpendicular side. He has in his hands a flat stone which is not very heavy. In one movement he must throw the stone over his head and jump down. The contestant throwing the stone the farthest is the winner. (5) In this event, called *Rkub rdo*, a target consisting of a pole with a red cloth tied to it is erected. The contestant follows the same procedure of event (4), but instead of throwing the stone blindly over his head, he throws it from between his legs, which, of course, allows him to see the target. The contest is judged on the accuracy of the throw. (6) This event, like event (5), has a target, but it is much farther away. The contestant carries a small round stone with his thumb, forefinger, and middle finger. He runs up the runway and throws the stone overhand when he reaches the jumping platform, but he does not have to jump over the edge. Distance and accuracy are the criteria used for judging.

Not all *Ldab ldobs* participate in *Mchong*, but those who do are grouped in clubs called *Gling ka skyid sdug*. These clubs are open to laymen and laywomen of any class. Lay members cannot compete in a competition, nor do they have any say in arrangements preceding a contest. But they can practice with the *Ldab ldobs*. The clubs are open to lay people because when an intermonastery competition is held, they can supply such things as tents, sofas, and food. If a lay member needs assistance in a physical job, such as building a house, he may ask the *Ldab ldobs* of his *Gling ka skyid sdug* to help him (but so can anyone who knows a *Ldab ldob* in or out of a *Gling ka skyid sdug*).² In *Se ra* monastery the two biggest colleges – *Se ra Byes* and *Se ra Smad* – each had two clubs, one for older *Ldab ldobs* and the other for younger ones.

² Beatrice Miller, "Ganye and Kidu: two formalized systems of mutual aid among the Tibetans", *S.W.J. Anthropol.* (Summer, 1950), pp. 165–66, says, "But their [*Ldab ldob*] Kidu [club] is open to both men and women of the laity. Any man or woman who belongs to this Kidu can call upon his fellow Kidu members for protection in case of trouble. Here the Kidu assumes a formidable role quite beyond the more usual, and more limited, interpretation of mutual aid." Miller has missed the main function of the *Ldab ldob Gling ka skyid sdug*, which revolves around the *Mchong* competition. Also, she implies that all *Ldab ldobs* belong to this club, when actually the membership is limited to those *Ldab ldobs* who participate in *Mchong*.

One of my informants, *Ngag dbang Nor nang*, became a member of the older club of *Se ra Byes* by telling a *Ldab ldob* friend who was a member that he would like to join and having the friend say, "Very well."

Mchong competitions are infrequent for several reasons, for example, the expense of building a jumping runway and getting supplies for the meet. Perhaps even more important, however, is the fact that a meet cannot be scheduled until the official administrations of the monasteries guarantee that there will be no fighting and killing before, during, or after the meet. This guarantee is put in writing and affixed with the seal of the monastery, and the administration must therefore actively supervise the competition. Thus, it is only when one *Gling ka skyid sdug* feels that it has an exceptionally good team that it will begin negotiations with a highly regarded club of another monastery. If two clubs agree, then the monasteries must decide whether they will allow the competition. If they do, then the two clubs select a site and time for the meet, with the approval of the monasteries, and select judges from the *Ldab ldobs* of the two clubs.

The *Ldab ldobs* come to the jumping field in their best garb, but competitors change to a different costume. They wear short pants with the torso bare except for a large red protective scarf blessed by a Lama (*Srung mdud*) tied around the neck and a *Rtsa sdom* tied on the right arm. They compete barefooted. Each side wears distinctively colored pants, although no monastery or club has any standard color. Any color – even white – can be used, and it is only on this occasion that the monks do wear white. The *Ldab ldobs* outside of Lhasa do not wear the garb I discuss above. They might wear only inner robes.

Teams usually consist of no more than twenty on a side, and the sides are always equal. Representatives of the two clubs meet first and decide which of their competitors will be paired off with those from the other monastery. The players are matched according to skill, and the same pairs compete against each other for all six events. The team that wins a majority of the two-man competitions wins that event. At the end of the six events, the side that wins a majority of the events wins the meet. Ties are not played off, but are left as ties.

The winners are presented with white ceremonial scarves (*Kha btags*), and the team members wear the scarves as they march to Lhasa after the presentation. The competition is attended by all officials of the two monasteries except the abbot (*Mkhan po*) and by large numbers of people from Lhasa (government officials, traders, and so forth). By helping to organize and attending the meets, the monastery officials accept the fact

that within a monastery there actually are monks who are called *Ldab ldobs*.

Although competitions are infrequent, the *Ldab ldobs* constantly practice the events on the permanent jumping platforms of their monastery. No interclub meets occur within a monastery. To become famous through jumping, a *Ldab ldob* must be outstanding in inter-monastic meets.

The *Ldab ldobs* also play other games, but none of these are on the grand level of the Lhasa *Mchong*. In other parts of Tibet, *Ldab ldob* competition is solely within a monastery. The *Ldab ldobs* in these monasteries have no rigid set of games; in fact, they often invent new games to test courage and skill. Games they play include: lifting stones to test the strength of competitors, throwing stones, running races, and wrestling (*Shed tshad*). In *Khams* there is a novel game called *Khu tshur tshad*. In this game two *Ldab ldobs* smash their fists together until one of them draws his fists back. One of my informants has seen monks bloody their hands in this game. Although the *Ldab ldobs* claim that they have eighteen different sports, most of these are also played by laymen. Laymen play all games except the *Khu tshur tshad* and the six events played in Lhasa.

More important than sports, the *Ldab ldobs* love fighting, either among themselves or with laymen. Within the monasteries the *Ldab ldobs* have a loose hierarchical structure which is dependent on their success as fighters. A *Ldab ldob* renowned as a great fighter has achieved the most highly sought after honor that a *Ldab ldob* can acquire. In fact, a *Ldab ldob* who does not fight, or who cannot win fights, is a *Ldab ldob* in dress only.

There are several types of *Ldab ldob* fighting. The first, which I call the challenge fight, occurs solely within a monastery and is not related to any personal grievance or quarrel between the combatants. The object is to see which fighter is stronger. Success in a challenge fight enhances the *Ldab ldob's* reputation more than any other accomplishment. Almost always this type of fight involves only two *Ldab ldobs*, but on rare occasions the number is increased to equal sides of two or three each.

A challenge fight is instigated when one *Ldab ldob* asks another, more renowned *Ldab ldob* in the same monastery to fight. If he agrees, they arrange a time and place to hold the contest – usually a deserted place quite far from the monastery. There are no rules concerning the type of weapons to be used. The contest may be held in private or in the presence of other *Ldab ldobs*. As I mentioned before, there is no animosity between

the two fighters, and they often go together to the "field of honor" chatting like old friends. However, once started, the contest continues until one of the combatants gives up and says that he is under the power of the other (*Nga khyed rang gi mnga' 'og yin*), or until one of them is too badly injured to continue the fight. These fights often cause serious injury to the combatants and sometimes even death. If it ends in death, the *Ldab ldob* is subjected to both monastic and secular punishments.

To illustrate the challenge fight, let me relate an incident which took place between two *Ldab ldobs* of *Se ra* monastery, one of whom was a friend of *Nor nang*. *Nor nang's* friend had previously lost his right arm in a nonchallenge fight with three *Ldab ldobs* from a *Khams Khams tshan*³ in *Se ra*. When he had sufficiently healed, he decided to regain his reputation and stature by challenging a famous *Ldab ldob* from the same *Khams tshan* as that of the three monks who had attacked him. The famous *Ldab ldob* accepted the challenge, and they arranged a time and place. The final outcome was that the one-armed *Ldab ldob* killed his opponent. In this case, the affair was hushed up, but apparently this is an exception.

The challenge fight is supposedly intramonastery. While on the surface this is the case, the *Ldab ldobs* often employ a deception which allows intermonastic fights similar to the challenge fight. When a *Ldab ldob* of one monastery becomes famous, the *Ldab ldobs* of another monastery may decide to test his reputation. Since they cannot formally challenge him, they have devised another method. One *Ldab ldob* volunteers to wait for him in a sort of ambush. When they meet, this *Ldab ldob* tries to provoke a fight verbally. If the victim deserves his reputation, he will need little encouragement. As in the true challenge fight, there is no personal grudge, and the number of combatants is equal. It is merely a test to determine which of the combatants is stronger.

My informants have seen one incident where two *Ldab ldobs* began fighting in a "grudge" fight. But when one said he was under the other's power, they became friends and walked away together. And my informants had also heard of many similar cases.

Another type of fighting between *Ldab ldobs* might occur after a dialogue such as this:

I. stwa re zla ba dkar chung/ a phrag sbug la bcug yod/
gros po'i thod pa'i dkyil la/ ta thā ga ta bri yong/

³ *Khams tshans* are the units in the larger monasteries in which the monks reside. Membership in these is contingent on geographic location. Monks from the same area live in the same *Khams tshan*.

I have put a *Khye'u* inside my *amdra* (pocket)
and will draw *ta tha ga ta* in the middle of your forehead, friend.

II. Gyas na lcags sag [khye'u] mi dgos/ gyon ma smyug krog mi dgos/
so dang sen mo gnyis kyis/ grogs po sbu shud gtong chog/

I don't need a *Khye'u* on the right, I don't need a pen-case⁴ on the left.
By teeth and nails, I can skin you, my friend.

The *Ldab ldob* also fights with laymen. Often without knowing the parties concerned, he enters into a fight on the side of the loser. This is one of the traits which endears him to the lay population. However, more frequently the *Ldab ldob* is the instigator.

A large proportion of the fighting between *Ldab ldobs* and laymen, and among *Ldab ldobs* themselves, hinges on the *Ldab ldobs'* general propensity for homosexuality, and from this, their most infamous characteristic of "kidnaping" young boys, and even adults, for homosexual practices. Among the monks in Tibet, and especially among the *Ldab ldobs*, homosexuality has a status similar to premarital sexual relations in our culture: it is sinful, but widespread. Among the Tibetan lay population, it carries an extremely derogative stigma and is almost unknown.

Although a monk who practices homosexuality is at the least committing the two sins of "sexual desire" (*'Dod chags*) and "perverse view" (*Log lta*), he will often rationalize that he is not breaking the prohibition to derive pleasure from the three doors (anus, mouth, and vagina) since, in Tibet, homosexuality is practiced only between the legs from behind. Any other practice is considered unthinkable. This relationship with a close relative is equally scorned, for the same taboo for incest applies here. Yet when we look at the following well-known saying of Gelugpa monks, we can readily see that *Ldab ldobs* or monks who practice homosexuality really do believe that they are committing a wrong:

Spyi dpon shakya thub pas ni gang yang gsung mi 'dub/
sger dpon blo bzang grags pas ni pom thog la bzhag gnang bzhag/
bar skabs pan 'grub 'ga' zhig gis rdzab chen nag gi sgang la
skyel bzhag/

The Universal Lord, Shakyamuni, didn't say anything about it
[homosexuality] at all.

On top of that, our private Lord, *Tsong kha pa*, left it as it was.
But in between these two, Pandits and "Enlightened ones" have put
us in with the most wicked of the wicked.

Pen-cases are often filled with sand or gravel and used as a sort of blackjack.

Kidnaping might begin with a *Ldab ldob* striking up a conversation with a young girlish-looking boy (either monk or lay). If the boy is not receptive to his advances, the *Ldab ldob* may forcibly lead the boy away. Unless the *Ldab ldob* has an arrangement with friends to use their house, he will have to take the boy back to the monastery in order to have privacy. If this is the case, the boy will be forced to spend the night there because of the distance between the monastery and Lhasa (using Lhasa and the three large monasteries as an example). *Ldab ldobs* are not reluctant about taking a boy from the aristocracy against his will, and some *Ldab ldobs* are even famed for taking nobles' sons. There are also instances where *Ldab ldobs* took adults, and even aristocrats who were government officials.

The *Ldab ldobs* are able to continue this behavior because their "victims" fear retaliation by the *Ldab ldobs*, but more because of the shame at having been a homosexual partner (*Mgron po*). In Tibet, the main stigma goes to the victim, or to the voluntary partner, and not to the doer, the *Ldab ldob*. We know from our own culture how strong this same type of stigma is in cases of rape and forced homosexuality, and it seems to be even stronger in Tibet, when the victim is a layman.

Yet, in accordance with the dichotomy in the *Ldab ldobs'* behavior, his kidnaping of boys is not necessarily one-sided. *Ldab ldobs* are noted for their generosity to their *Mgron po*, which, in the case of the lower classes, partly soothes the shame.

With this brief background, the relationship of homosexuality to fighting becomes evident. Usually *Ldab ldobs* will fight to determine who owns a voluntary *Mgron po*. Since these fights are spontaneous and unconcealed, they are the most common ones in which the *Ldab ldobs* are caught and punished by the monastic officials, both for fighting and for homosexuality.

Fighting occurs when laymen try to avoid kidnaping. School children are the prime targets of *Ldab ldobs*, and the close of school each day the prime time. Trouble starts when the school boys get word that *Ldab ldobs* are waiting for them. They may then plan a way to turn the tables on the *Ldab ldobs*. Since all school children carry a small pen knife to sharpen their bamboo pens, they have a weapon of a sort. If the children can manage to down the *Ldab ldobs*, they can inflict serious injury on them, and my informants knew of several incidents where the *Ldab ldobs* were killed. These were not common, however. Usually the school boys go in groups, and when they meet the *Ldab ldobs*, hold them off with barrages of rocks.

Phyi'i lcags ri
nang gi no'bu

(We *Ldab ldobs*) are the outer wall,
(The other monks) the inner treasure.

This *Ldab ldob* saying tersely summarizes the main function of *Ldab ldob* within the monastic segment of Tibet. The *Ldab ldob* is the backbone of the monastery. He performs the majority of the manual labor in the monastery – building a new house, making tea, or transporting goods from place to place. At the time of *Smon lam*⁵ and *Tshogs mchod*⁶ in Lhasa, the monks of 'Bras spungs are put in charge of that city. The head of the monastic police force is the *Zhal ngo*. Under him there is a large force of *Dge g.yog* (*dge skos g.yog po*) who are recruited from the *Ldab ldobs* and who function as police during the two religious holidays. The *Ldab ldob-dge g.yog* wears the entire *Ldab ldob* outfit except the *Rna skra*. In *Khams*, also, the *Ldab ldobs* are used for police purposes at the time of religious processions. The *Ldab ldobs* march at the head of processions clearing the road of crowds. They too wear the complete *Ldab ldob* garb, but including the *Rna skra*, and they wear hats in accordance with their sect.

The police function of the *Ldab ldobs* does not cease when there are no religious ceremonies. Whenever the religious officials of the monastery have to travel to remote areas, *Ldab ldobs* serve as bodyguards. In this function, they usually wear traveling clothes (*Phyogs chos*) instead of their religious dress. Also, nobles and traders often take *Ldab ldobs* along for protection on a trip of any distance.

Ldab ldobs can be *Dge rgan* to new monks, since they can bypass the teaching duties of a *Dge rgan* by sending their charge to another "normal" *Dge rgan* to study. This distortion of the role of *Dge rgan* is not surprising. The concept of *Dge rgan* is one of the foundations on which the monastic system is constructed. To his pupils, the *Dge rgan* is teacher, discipliner, provider, and the figure in the monastic social system to whom the young monks can transfer those feelings of love and permanency which in the secular world are directed toward the father and uncles. Because of this, the parents of prospective monks attempt to find a relative to act as *Dge rgan* for their son. If such a relative is available, the boy is almost always put under his tutelage, regardless of the level of the relative's

⁵ *Smon lam* is the religious prayer festival started by *Tshong kha pa* which takes place in the first Tibetan month.

⁶ *Tshogs mchod* is the religious festival in the second Tibetan month commemorating the death of *Tsong kha pa*.

knowledge. It is thus through his kinship relations that the *Ldab ldob* becomes a *Dge rgan*.

Ldab ldobs are a phenomenon of youth. By the age of forty they “outgrow” this role and assume new ones in the monastic system. Some enter the administrative hierarchy of monasteries, becoming disciplinary officials (*Dge skos*). Others become *Dpe cha ba*, monks who study advanced religious texts. Most *Ldab ldobs*, however, enter the category of the majority of monks, *Sgrogs med*, who do not read advanced texts, but maintain their vows. Sometimes a *Ldab ldob* will become famous for his erudition as a Buddhist scholar. The informants had heard of instances where former *Ldab ldobs* became abbots (*Mkhan po*) of monasteries and stories that they had even become “enlightened” (*Grub thob*).

Although *Ldab ldobs* repeatedly break the basic monastic laws, the punishments inflicted by the monasteries when they apprehend the culprits – usually prostrations or beatings on the buttocks with switches – are neither severe enough nor frequent enough to discourage the *Ldab ldobs* from continuing their behavior. The monasteries’ reasons for allowing *Ldab ldobs* to remain, and the *Ldab ldobs*’ reasons for wanting to stay, warrant examination.

Because its members do not leave and its problems are solved within the monastery, the monastic system is a closed institution. Only a small percentage of monks withdraw from the system, perhaps as small as 2 or 3 per cent. There seem to be several reasons for this fidelity. In the first place, the prestige of monkhood is enormous. A monk wears the robes of the Buddha and is a sentient being who has withdrawn from the illusory material life and entered the road to enlightenment. There is a Tibetan saying which illustrates this idea:

nga yi dge sbyong tshul khriims nyams su gyur kyang/
phyi rol drang srong gzhan gyi do zla med/

Even though my practice of virtue has become disintegrated
still I am on a higher level than a learned man who is not a monk.

Thus, taking vows elevates a monk higher than any layman.

There is also great economic advantage to be gained from monkhood. The life of a monk, even those who do physical labor, is not difficult, especially in comparison to life in the village. Monks do not have material concerns about the future, about food or money, about taxes, about droughts or floods, for the monastery takes care of their basic needs. Monks get an allowance in kind and money, partly from the

monastery and partly from the trust funds set up by laymen for the monks in a particular monastery. This basic “wage” is sufficient for their minimal material needs, and it can easily be supplemented through either religious or secular outside work.

Some negative pressures also keep monks in the monastic system. The most important of these is economic. If a monk decides to leave the monastic system, the opportunities available to him are greatly limited. If he can go home to his family, he may not have the same rights as his other non-monk brothers. If he cannot go home, where can he go? In Tibetan society the difficulties of finding a new role are formidable and are therefore an important factor in keeping monks in the monasteries.

Tibetans do not consider the *Ldab ldob* to be the worst monk; he is bad, to be sure, but he is not among the worst. In Tibet, monks generally are noted for their nonattachment to wealth and to people, and *Ldab ldobs* are particularly noted for possessing this very important characteristic. They are shortsighted in respect to future plans and live without thoughts or worries concerning the future. This nonattachment carries over into another area. A *Ldab ldob* does not have the burden of “perverse livelihood” (*Log 'tsho*), which is the earning of money for religious services rendered. Tibetans have a saying which elucidates this non-attachment (it also could be used for other monks than *Ldab ldobs*):

'Gyel na spos 'gyel ba bzhin
Langs na spos langs ba bzhin
Mgo nas 'jus na skra sbar gang
Rkub nas 'jus na dug tshal sbar gang

If I fall, I fall like an incense stick (alone),
If I rise, I rise like an incense stick,
If someone grabs my head, he gets only a handful of hair,
If someone grabs my buttocks, he gets only a handful of old rags.

A famous example of this type of nonattachment attitude of the *Ldab ldob* is *Dbang'dud*, one of the most noted and fierce *Ldab ldobs* of the modern period. He would give all his money to the Lhasa beggars and then feed himself by eating in the cafes in Lhasa without paying. All of the Lhasan informants knew of *Dbang'dud* and this particular feature in his behavioral pattern.

One of the most prized characteristics in Tibetan society is honesty, in the broad sense of nonhypocrisy and straightforwardness. The worst monk is not one whose outward behavior is bad, but rather one who is hypocritical and perverse in his thoughts. Let us examine this briefly through a type of monk called '*Jig rten chos brgyad* (this is strictly the

colloquial use of the term). He is a hypocrite because outwardly he acts holy and pious, but in his mind he is actually not. He prays loudly when people are around, but for the impression he will make rather than from belief. An incident which occurred in Eastern Tibet illustrates the Tibetan reaction to this type of monk. There were two high monastic degree holders (*Dge bshes*) who were very antagonistic. One day one of them told his servant to make tea, for he had very good news to tell. The servant anticipated that the *Dge bshes* would discuss some new religious teaching he had heard, but instead, the *Dge bshes* told the servant that he knew for a fact that the monk he did not like had had sexual relations with a woman. The servant lost his faith in the *Dge bshes* because he was happy over the disgrace of another monk. Turning against his master, the servant spread the story, explaining why the *Dge bshes* was so happy. At that time a Lama from *Dga' ldan* monastery happened to be in the area. When asked his opinion on the incident, he said that the *Dge bshes* who was so happy was worse than the *Dge bshes* who had actually broken his vows of celibacy. He continued that despite external acts, it is finally the internal truth which counts most. Therefore, the *Dge bshes* who was so pleased by the incident, rather than having compassion for the fallen monk, had very little religion within him, even though he broke no vows and knew texts.

A more contemporary example of Tibetan concern with hypocrisy is the case of *Dge bshes Blo bzang*, a Mongolian monk who had attained the highest monastic academic degree, *Lha ram pa*. *Blo bzang* was a strange man. Although extremely brilliant, his outward behavior was appalling. He smoked and seemed to have a penchant for gambling of any kind; he would play *Mah-jongg* with two cigarettes dangling from his mouth. He loved the horse races, dice games, and cards. His language was crude, and except when debating religion, he was almost never serious. He teased girls and continually told pornographic jokes, but he never broke his vow of celibacy. He considered everything to be a subject for his jokes and ridicule. In 1960, His Holiness, the Dalai Lama appointed this *Dge bshes Blo bzang* to the post of abbot as the spiritual leader of the largest refugee camp for monks in India (Boxa). Of course, given the new responsibility, *Blo bzang* changed his behavior, but the point of this incident is that the Dalai Lama paid no heed at all to *Blo bzang's* outward behavior, rather basing his judgment on the inner worth of the man. This dichotomy between what is perceived and what is real is very important for understanding Tibetan society, and especially *Ldab ldob*.

The use of the term *Ldab ldob* attributively clearly shows the attitude of laymen, and even monks, toward *Ldab ldobs*. When a layman is said to be like a *Ldab ldob*, it simply means that he is someone who is frank and forthright in his dealings with others. He calls a spade a spade, but not to excess or with the aim of hurting the other person. He is crude and unsophisticated, but not in a derogatory sense. For females the same holds true, except that there is the added connotation of "tom-boy".

I have tried in the descriptive sections of this paper to present a picture of a deviant type of monk synchronically from the viewpoint of the "little tradition" and the "little community", in contradiction to the "great tradition". By "great tradition and community" I mean the corpus of Buddhist texts (Kanjur, Tanjur, and so forth), the higher intellectual levels of the monastic order (the scholars and speculative thinkers concerned with the above-mentioned corpus), and a very small number of lay intellectuals. All the rest of the population I put into the "little tradition". My aim was to view this one aspect of Tibetan society separately from the historical or speculative aspects of the "great tradition". To analyze the *Ldab ldob* or any other element in the society from the standpoint of the "great tradition" has little value for understanding the actual society of the "little tradition", the "little community". To draw levels of the culture – for example, a lower level of shamanism or animism, a level of Hinduism, or even different traditions of Buddhism – is to make a distinction which the "average" Tibetan does not make. Although the values of the "great tradition" are certainly related to the "little tradition", they are not the same (as is obvious in the case of the *Ldab ldob*) nor are they necessary for an understanding of the culture of the "little community". According to the values of the "little community", the phenomenon of the *Ldab ldob* is neither bad nor good, merely unique.

Throughout the latter half of this paper, I have implied that there is a functional purpose for the *Ldab ldobs* as a group. The *Ldab ldobs* are a channel by which the monastic institution absorbs deviants and gives them a useful role within the institution and a place both in monastic society and Tibetan society in general. By this device, the monastic order is able to change potentially hostile members into productive members; potential anti-monastic elements into completely pro-monastic elements. Additionally, the monastic institution can finally bring these deviants back into the fold of the normal monks (as is evidenced by the fact that there are basically no *Ldab ldobs* over forty years of age). It is highly significant that despite the antisocial, aggressive nature of the *Ldab ldobs'*

behavior, there has never been a *Ldab ldob* revolt against a single monastery or against the entire system. In fact, *Ldab ldobs* do not play any role at all in anti-monastic politics. It would seem that the Tibetan monastic system has evolved an equilibrium which possesses an impressive degree of efficacy.